



# **BXM 554 KR / BXM 754 KR**

Conveyorized membrane skinning machines

**MEMBRANE SKINNING**



**MAJA**<sup>®</sup>



The BXM KR is suitable for continuous membrane skinning of flat cuts. The product is positioned on the infeed conveyor belt and the first side is skinned. A return conveyor sends the product back to the operator who positions the product once again on the infeed conveyor. The second side is then skinned. Membrane is collected in an EII membrane box placed under the machine or onto a lateral discharge conveyor.

# BXM KR

## Strong points:

- Continuous skinning of flat meat cuts from both sides with automatic machine solution
- Controlled product infeed
- Tooth-roller cleaning by patented MAJA Cleaning Roller System – completely without compressed air
- BXM 554 & 754 KR: no removal of the blade holder for blade changing and cleaning  
BXM 554 KR: changing and adjustment of the blade through quick-locking device
- Very easy handling
- High automation
- Cost-saving solution
- Hygienic machine design

## Your profit:

- ➔ High product throughput; processing of flat cuts without risk of injury for the operator
- ➔ Constant skinning result
- ➔ Machine installation independent from compressed air connection; no costs for compressed air supply
- ➔ Quick and safe changing of blades, easy cleaning
- ➔ No need of qualified staff
- ➔ Time savings - cost savings - high profitability
- ➔ Short amortization
- ➔ Quick and easy machine cleaning

TECHNOLOGY FOR THE FUTURE

## Equipment & features:

- Feedback conveyor belt (KAB 500)
- Spring-mounted infeed conveyor belt
- Infinitely variable thickness setting
- Patented MAJA Tooth-Roller Cleaning System without compressed air
- Divided discharge conveyor belt

## Options:

- Standard discharge conveyor belt
- BXM 554 KR**
- Lateral discharge conveyor belt (KAB 270)

**MAJA**<sup>®</sup>

# APPLICATIONS

Product	Before Skinning	After Skinning	Ø Average weight of cut in kg:	Ø Average capacity in kg / hour:
<b>Brisket</b> (Beef - boneless)			1,8 – 3,0	1.080 – 1.800
<b>Chuck</b> (Beef - boneless)			0,5 – 2,5	600 – 1.500
<b>Clod</b> (Beef - boneless)			0,4 – 2,0	480 – 1.200
<b>Flank</b> (Beef - boneless)			0,3 – 0,8	360 – 960
<b>Silverside heel</b> (Beef - Boneless)			0,4 – 1,0	480 – 1.200
<b>Cap of topside</b> (Beef - boneless)			0,8 – 2,0	720 – 1.800
<b>Rump tail</b> (Beef - boneless)			2,0 – 4,5	2.400 – 3.400
<b>Inside/Outside skirts</b> (Beef - boneless)			0,2 – 0,6	120 – 360
<b>Loin</b> (pre - skinning) (Pork - boneless)			1,8 – 4,0	1.080 – 2.400
<b>Different parts of leg</b> (Pork - boneless)			0,8 – 2,4	960 – 1.900

### Technical Data:

Type	Cutting width mm	Width with/without conveyor belt KAB 270 mm	Depth mm	Height mm	Electrical connection 3AC/50Hz/400V kW	Weight kg
BXM 554 KR	554	996 / 1853	2204	1367	1,5	620
BXM 754 KR	754	1196 / 1853	2204	1367	1,65	650

BXM KR 3 / 2009 GB  
Technical details subject to change without notice.

### BXM 554 KR

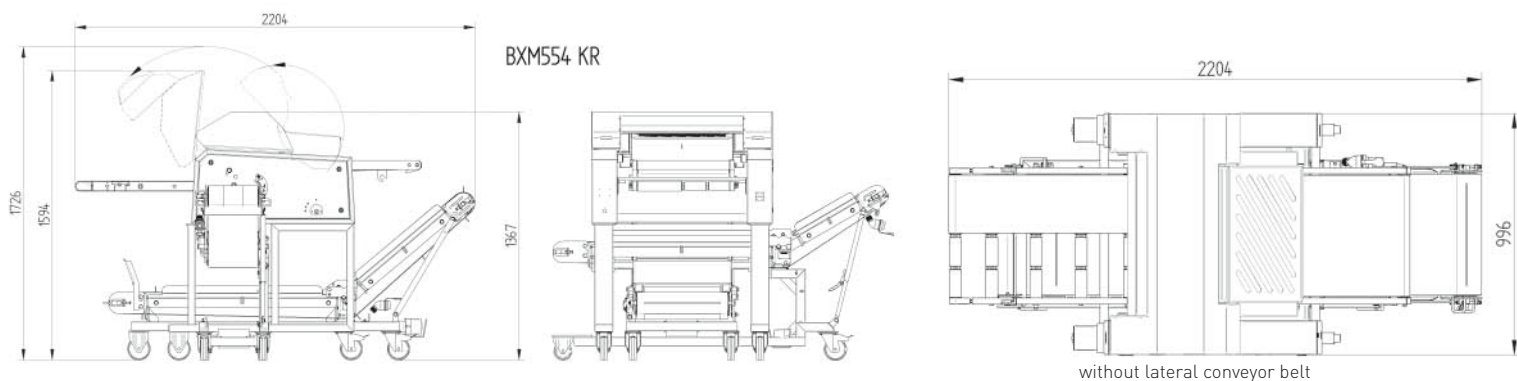

without lateral conveyor belt

### BXM 754 KR

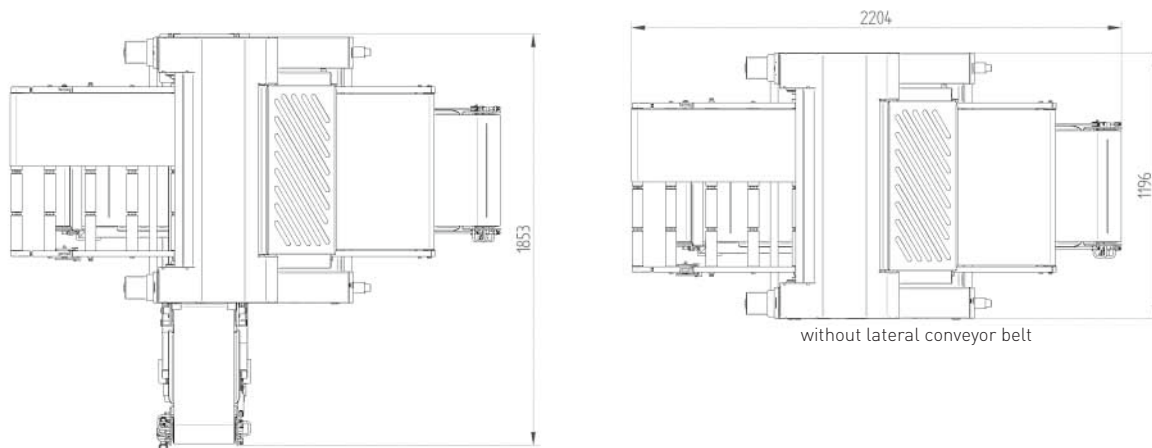

without lateral conveyor belt