

EMULSIFIER

INNOVATIVE SOLUTION FOR THE EFFICIENT MANUFACTURE OF YOUR PRODUCTS

FZ 175
FZ 225



APPLICATIONS OF THE LASKA EMULSIFIERS

The most impressive thing about the emulsifier is the unrivalled product quality in this class of emulsifiers permitting production volumes in the medium and high range. The machine produces stable and fine emulsions while being gentle on the material, keeping entrapped air at a minimum, and optimizing energy consumption. The decisive aspect is the innovative electro-hydraulic knife adjustment which ensures high production quality at a very low wear of the cutting set. The elaborate system is successfully applied worldwide for the following applications:

- › **Production of scalded sausage**
- › **Production of cooked sausage and pies**
- › **Vegetable, cheese, etc.**

STRENGTHS AND BENEFITS

The homogeneous base material to be processed is pumped through the cutting set at partial vacuum conditions. This leads to emulsification and ensures the desired fineness of the product, with the fineness of the sausage meat being determined by various holeplates. After the emulsification process the desired final temperature is controlled via the outlet valve.

The emulsifier can be perfectly integrated into various forms of production processes. Together with the LASKA SuperCutter or LASKA mixers it stands for highest flexibility in terms of recipe and raw materials composition. The convincing features of the emulsifier are its very high throughput, easy handling, its unrivalled product quality and highest efficiency. Being provided with a filling level sensor and automatic emptying function as optional features, it turns to account as an important element in production lines for fine sausage meat.

QUALITY PROVEN IN USE

Just like all other LASKA machines, the emulsifiers are made of solid stainless materials. They meet strict hygienic requirements and are easy to clean. The design allows for the rigorous operating conditions, easy and safe operation, and good access for servicing.



HYGIENE AND SAFETY

- › Safety ensured through closed attachment and integral safety measures
- › Polished surfaces for highest possible hygienic standard
- › Safe handling due to safety guard in front of cutting set

OPERATION

- › Easy handling and user-friendly operating elements
- › Swivelling touchscreen with language selection
- › Substantial reduction of operating and maintenance errors

THE LASKA NANOCUTTER

YOUR BENEFITS AT A GLANCE

PRODUCTION

- › Stable emulsions of maximum fineness due to innovative knife adjustment
- › Gentle processing of the material
- › Minimum amounts of air entrapped
- › High stability of emulsion
- › High hourly output

LOW OPERATING AND MAINTENANCE COSTS

- › Cutting geometry and innovative knife adjustment result in constant pressure conditions at the cutting edges and holeplates
- › This reduces wear and cutting set abrasion by up to 50%.
- › The cutting set is monitored continuously and can be maintained preventively.
- › Display of servicing times
- › Easily accessible inspection doors
- › Worldwide service network and competent local support on all continents

DESIGN

- › Compact and space-saving design with integral control cabinet
- › All drive elements accommodated in the machine housing to prevent soiling
- › Automatic stop of the machine in case of running idle (extended service life of the cutting set)
- › Flow-optimized cutting geometry to reduce energy consumption
- › Noise reduction due to sound insulation inside the machine and low-noise drive technology



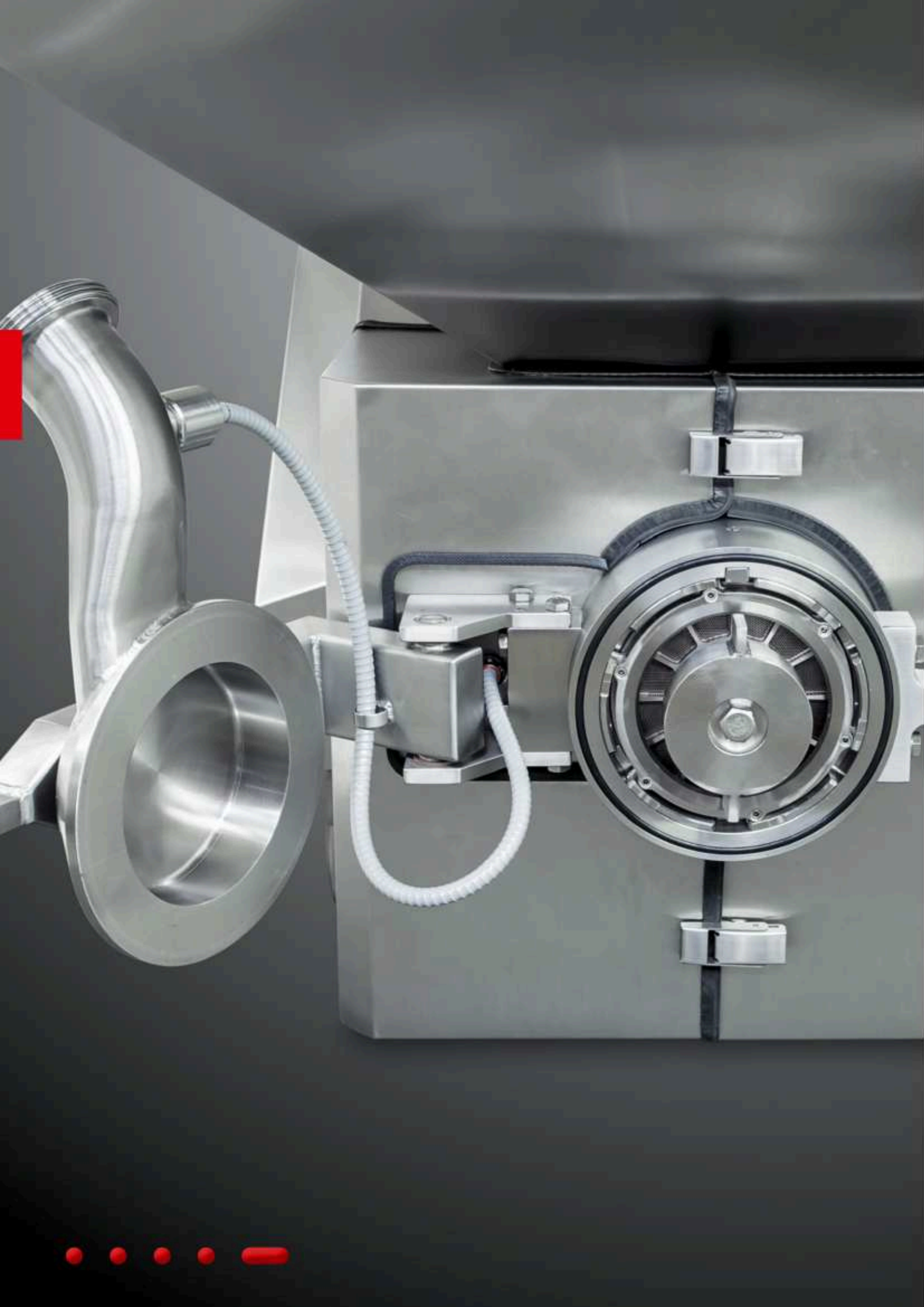

THE PATENTED KNIFE ADJUSTMENT OF THE LASKA EMULSIFIERS

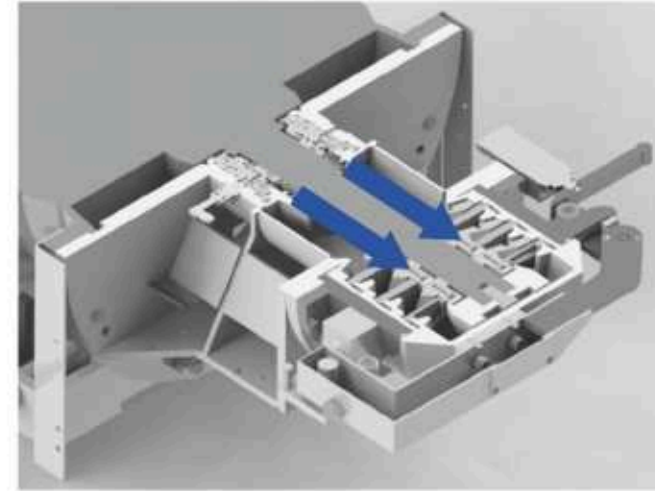

INNOVATIVE CONTROL CONCEPT

The key element of the NanoCutter is the patented electrohydraulic knife adjustment. The selectable pressure between the rotating cutting knives and the holeplates determines the fineness of the end product. It is controlled and corrected via a hydraulic system hermetically sealed against the product area.



QUALITY THAT TURNS TO ACCOUNT

To reduce the costs for wear parts such as knives and holeplates, the NanoCutter keeps the contact force as low as possible at all times, thus clearly reducing wear. This means that cutting set costs are reduced by up to 52 % compared to conventional emulsifiers.

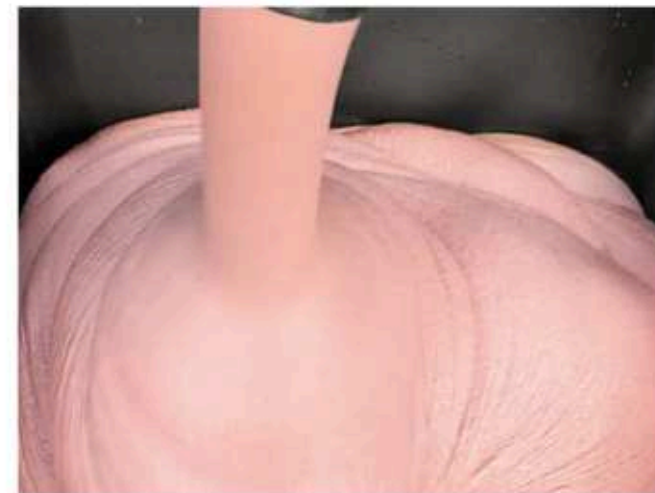

ALWAYS AT THE OPTIMUM WORKING POINT

Other than with the NanoCutter, the cutting set of many conventional emulsifiers is either positioned and readjusted manually, or with automatic adjustment only in increments. This results in a loss of contact force, on the one hand, and in high wear and



eventually in strongly varying final processing results, on the other hand. The NanoCutter, however, ensures a consistent processing result due to permanent control and automatic regulation of knife adjustment, and thus an optimum end product.

EQUIPMENT FOR YOUR LASKA EMULSIFIERS



CUTTING SYSTEM

- › Optimized design and unique cutting set geometry for high throughput and optimum emulsification while ensuring a cutting effect going easy on the product
- › Easy exchange of knives and holeplates without complicated tools
- › Automatic knife adjustment
- › Exchangeable hardened knives with high durability of the edge

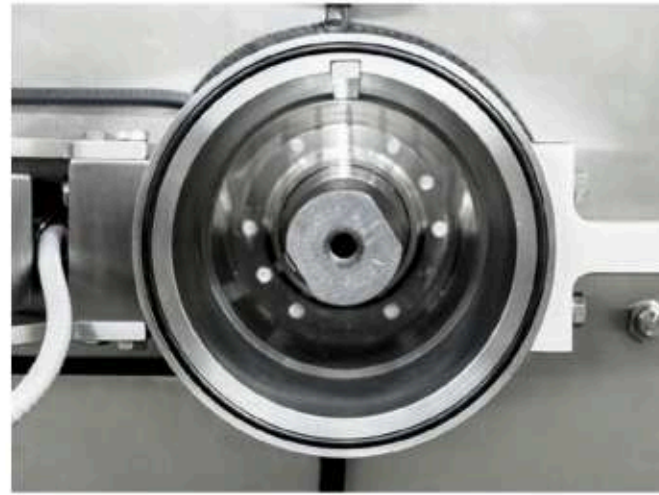

CUTTING CHAMBER AND DRIVE SHAFT

- › Smooth installation space facilitates cleaning
- › Easy installation of the cutting set
- › Best hygiene and error-free operation



MOBILITY

- › Electrical equipment integrated in the machine housing
- › Flexible and easy combination with other machines possible
- › Mobile design with lockable castors
- › Easier cleaning



TOUCHSCREEN CONTROL

- › User-friendly and clearly arranged
- › Large and easily legible colour display
- › Swivelling, space-saving
- › Language selection
- › Automatic malfunction display



MACHINE HOUSING

- › Solid stainless construction
- › Maximum protection from dirt and comfortable cleaning
- › Drive elements in closed machine housing
- › Optimum serviceability due to easily accessible inspection doors

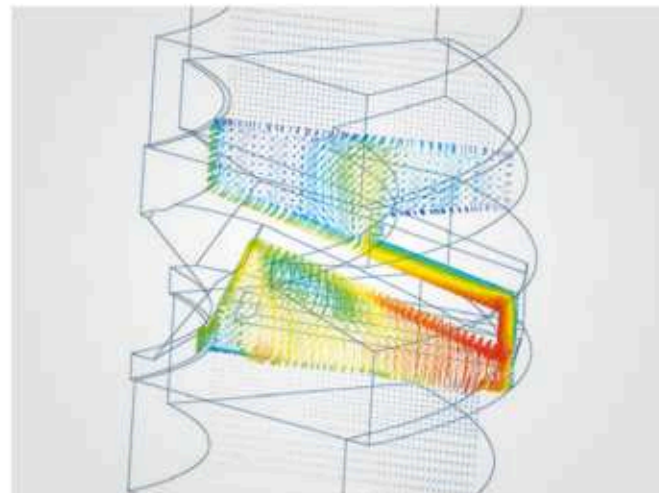

PRODUCT FLOW

- › Excellent product flow and fluid flow characteristics in the cutting chamber due to intensive research and use of state-of-the-art simulation and analysis methods
- › Best possible throughput
- › Perfect emulsification effect



AUTOMATIC CLEANING MODE

- › Cutting set relieved at the push of a button
- › Cleaning process due to relieving of cutting set virtually without wear



RECORDING OF OPERATING DATA

- › Continuous recording of temperatures, current consumption and wear of cutting set
- › For conclusive data to optimize the production process



OPTIONS
FOR YOUR LASKA EMULSIFIER

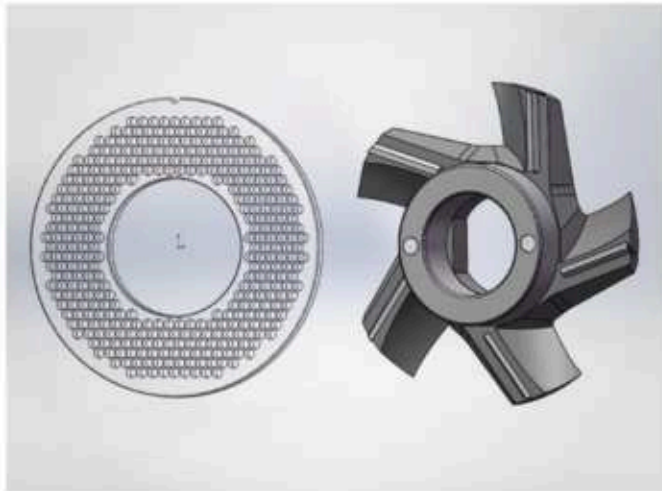

HOLEPLATES AND CUTTING KNIVES

- › Holeplates: with hole diameter 0.8 – 8 mm (standard: 1.2 / 2 / 3 mm)
- › Cutting knives: with 5 or 3 blades and exchangeable knife blades



AUTOMATIC TEMPERATURE CONTROL

- › Desired final temperature of sausage meat freely adjustable
- › Temperature permanently controlled via electrically controlled valves





THAT'S WHAT OUR CUSTOMERS SAY ABOUT THEIR LASKA NANOCUTTER



**ANDRÄ HÖRTNAGL PRODUKTION
UND HANDEL GMBH**
AUSTRIA

"We use the NanoCutter for manufacturing selected products. The constant product quality has convinced us and our customers. Fineness, little air entrapped, and a regular texture are the ingredients for our products "For Smart Eaters".

In terms of operation, the NanoCutter is a very economical machine. The long service life of the cutting set, too, makes things easier for us. The promised features of operator convenience, a low noise level, and easy cleaning have clearly come true."

MR. RESCH
PRODUCTION MANAGER

GOLDSCHMAUS NATUR GMBH & CO. KG
GERMANY

"The NanoCutter is the ideal complement to our existing bowl cutter. Especially for products demanding highest performance and emulsification, the NanoCutter has proven its worth in daily use.

Another remarkable feature is the excellent feeding effect of the NanoCutter. It enables us to process very compact sausage meats reliably and quickly with the NanoCutter."

MR. PRESTEL
PRODUCTION MANAGER

TECHNICAL DATA PERFORMANCE LIST



PERFORMANCE CHARACTERISTICS

| TYPE | | FZ 175 | FZ 225 |
|---|--------------------|------------------|------------------|
| Holeplate Ø | mm | 175 | 225 |
| Number of holeplates | | 3 | 3 |
| Connected load | kW | 90 | 132 |
| Operating noise | dbA | 80 | 80 |
| Hopper volume | litres | 200 | 200 |
| Throughput ¹ | t/h | 2,5 - 8 | 5 - 15 |
| Available holeplate bore diameters | mm | 0,8 - 8,0 | 0,8 - 8,0 |
| Reduced motor output | kW | 75 | 110 |
| Control system | | PLC ² | PLC ² |
| Starting reactor "soft start" | | o | o |
| Automatic regulation of discharge temperature | | o | o |
| Special voltage | | o | o |
| Fuse | A | 160 | 250 |
| Feed pipe cross section | mm ² CU | 70 | 120 |



DIMENSIONS AND WEIGHTS

| TYPE | FZ 175 | FZ 225 |
|----------------------|--------|--------|
| Length mm X | 2130 | 2216 |
| Width mm Y | 1168 | 1168 |
| Hopper height mm Z | 928 | 972 |
| Weight kg | 1300 | 1500 |

SEAWORTHY CASE*

| | | |
|-----------|------|------|
| Length mm | 2650 | 2650 |
| Width mm | 1500 | 1500 |
| Height mm | 1600 | 1600 |
| Weight kg | 550 | 550 |

* depending on type of transport

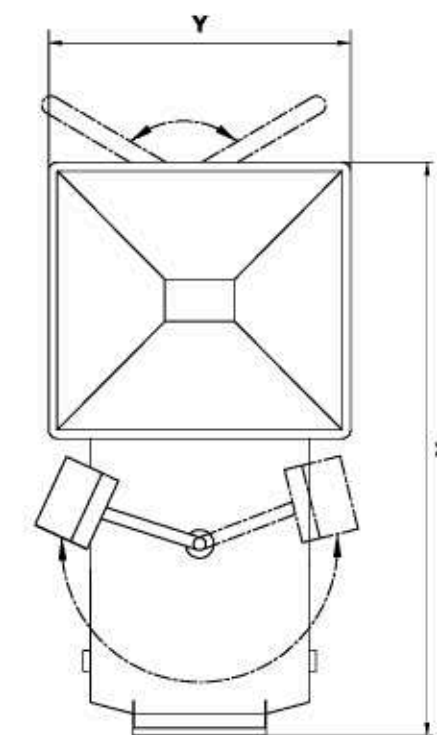

CAPTION

| | | | |
|---|--------|--------------|--|
| o | Option | ¹ | Statistical value; the actual values for your product will be established in a test run on request |
| | | ² | Micro process control |

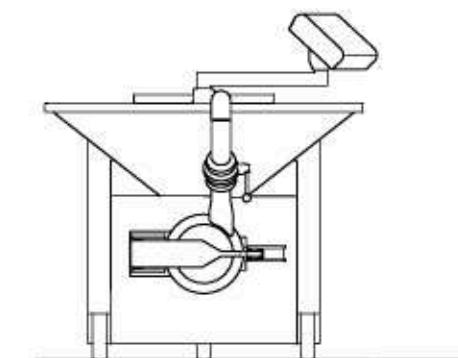
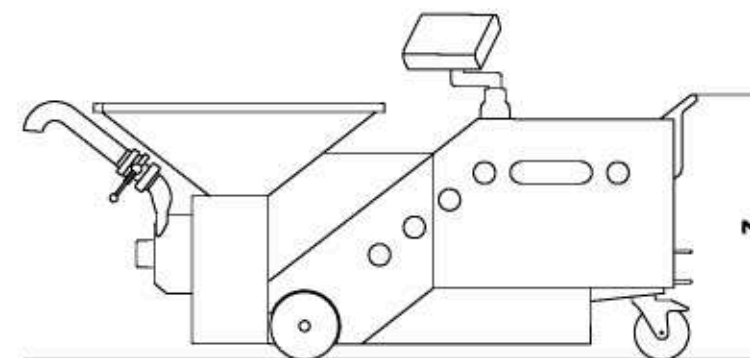

TRADITION & INNOVATION

MORE THAN 130 YEARS OF EXPERIENCE



Since 1880, the family enterprise has been active as a supplier of the food industry and closely associated with the latter. The machines produced by LASKA are high-grade products made of stainless steel featuring a number of auxiliary equipment.

Although LASKA is generally known for the best processing of meat, there are numerous other applications in practice, such as the processing of grease, cheese, fruit, vegetable, yeast, pasta, sweets, etc.

Today, LASKA machines are famous for their high quality in more than 130 countries on all continents, where they work to the complete satisfaction of national and international customers.

OUR PRODUCT RANGE:

- Cutters
- Grinders
- Frozen meat cutters
- Emulsifiers
- Mixing machines
- Production lines



Maschinenfabrik LASKA Gesellschaft m.b.H.

Makartstraße 60, 4060 Traun – Austria

P +43 7229 / 606-0

F +43 7229 / 606-400

laska@laska.at

www.laska.at

DEALER/PARTNER

